



Leclerc Looms

Since 1876



1573 Savoie
C. P. 4
Plessisville, Qc.
G6L 2Y6

TEL: 819-362-7207
FAX: 819-362-2045

DOROTHY 15 3/4"

- 2110-0000 4 SHAFT LOOM**
- 2111-0000 8 SHAFT LOOM**
- 2112-0000 12 SHAFT LOOM**



PARTS AS SHIPPED:

- 1 pre-assembled loom
- 1(2 or 3) head(s) 4 shafts (8s or 12s loom)
- 4 (8 or 12) screws #12 1 1/4" (for the head)
- 1 Multi bits screwdriver
- 2 cranks (long)
- 1 reed 12 dents per inch
- 400 wire heddles 9 1/2"
- 1 boat shuttle 6122-0000 (SLIM)
- 1 reed and heddle hook 6141-7000
- 2 lease sticks
- 10, 12" (31 cm) loop cords for lashing
- 2 (steel) warp rods
- 1 book Warp and Weave
- 1 Friction break wing nut

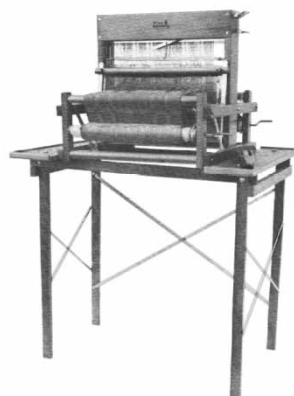

Loom Prepared by: _____

Inspected by: _____

Date: _____

Note in french:

Pour un métier 8 lames, mettre le cliquet de tête plus haut et identifier que la tête #1 va à l'avant et la tête #2 au centre.
Pour un 12 lames, mettre la tête avec cliquet plus haut à l'arrière.

A specially made table is available for the Dorothy 15 3/4"
Item # 6312-2000

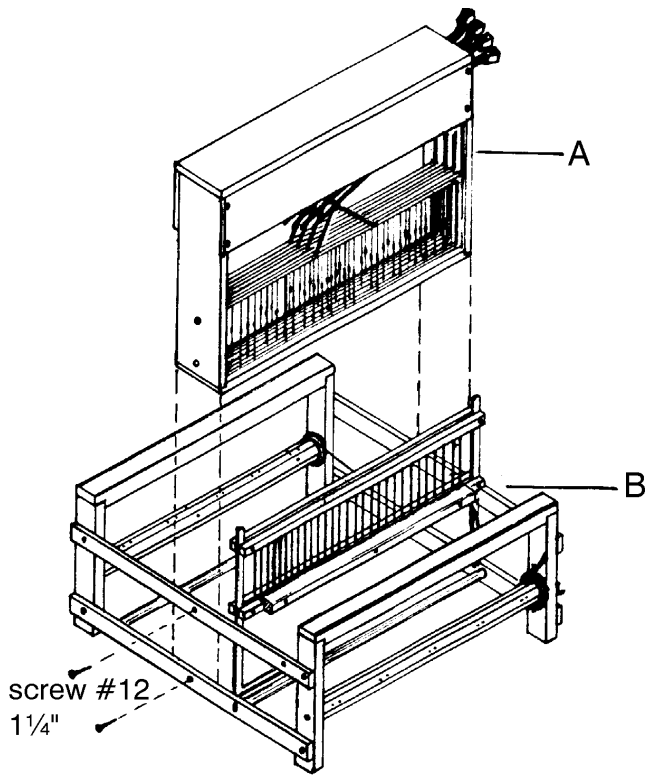

After unpacking the loom, unfold the base and put the two little metal hooks (at the front side) in position (over the screws) and screw them in slightly so they hold in place. Take off the machine screws which are at the end of the beams and attach the crank to the right hand side by turning it. Because the metal of the crank is plated, it may be little difficult to attach the crank but take your time, it is the right size. Push and turn on the right hand side slowly.

To set up the loom, put the head section A containing 4 shafts in the bottom frame B and attach each side with the 4 screws.
 Note: When installing the screws, take care to ensure that they go into the pre-drilled holes in the shaft frame and not in the wood beside, above or below. The screwdriver should turn easily with minimum resistance if this is being done correctly.

The reed can be removed easily by loosening the screws and raising the top piece.

To install the heddles, remove the heddle support by curving it slightly. Distribute them evenly within the shaft frame. There are enough heddles to weave full width with 24 threads per inch.

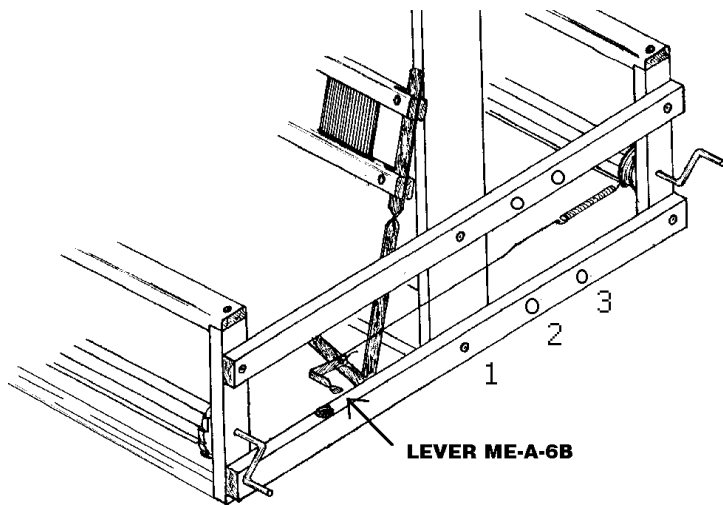

If the loom has only 4 shafts, the short frame have only one set of hole in the middle.
 If the loom has 8 shafts (long frame), put shaft section #1 in the front (1) and shaft section #2 in the middle (2) position. If your loom is a 12 shaft one, shaft section #1 goes in the front, #2 in the middle and #3 goes in the back (3).

Head section #2 and #3 have lever catch set higher so the shed is clear.

Friction Brake

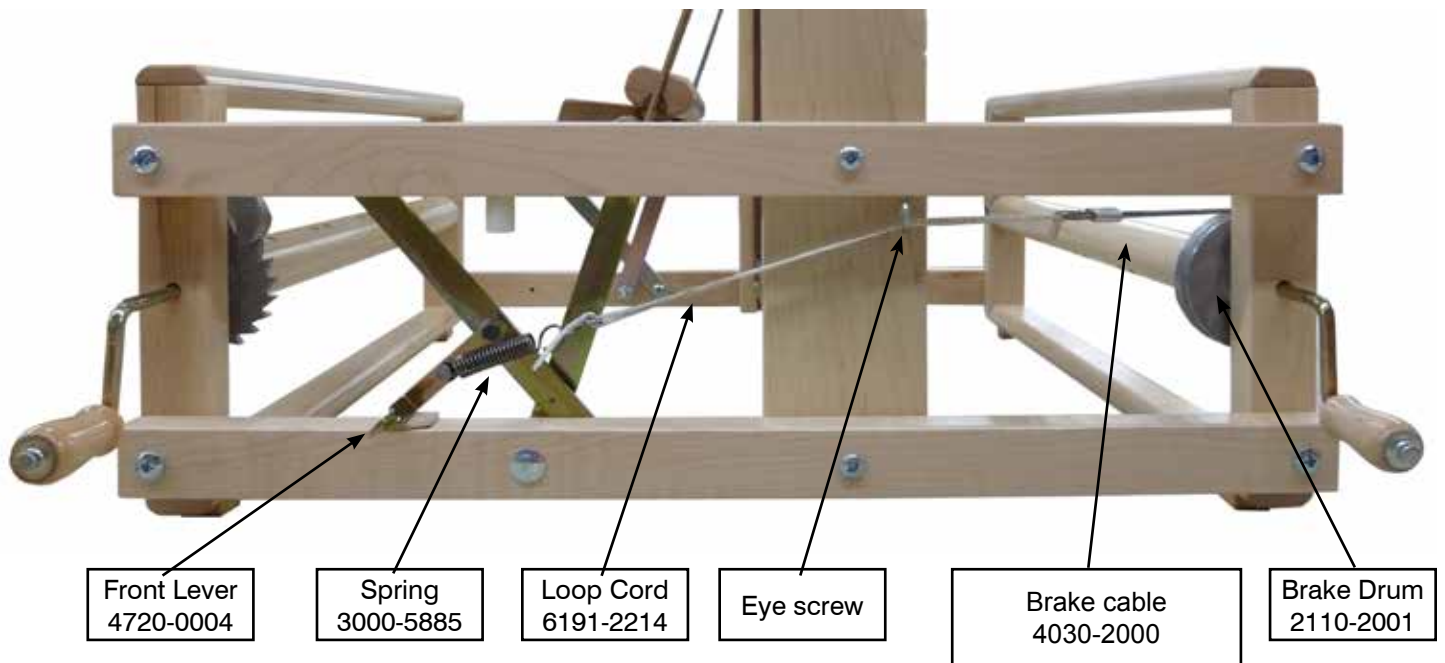

The length of the loop cord has been marked and tested before shipping. After some time, the loop cord may stretch. You will then have to reajust the tension by changing to the next loop on the cord.

To advance the cloth, pivot the front lever to the back of the loom in order to release the tension on the brake cable. When sufficiently advanced, pivot the lever back to the front to re-establish the tension on the brake. Tighten the warp with the warp beam crank.



Brake assembly with brake cable. Make sure that it is properly in place.



Move it up to release the brake.



Brake lever closed to tighten the brake cable.

Adjust the height of the reed so the bottom warp threads just touch (or are just a little lower than) the shuttle race when the shed is open.

Shed should be at least 1½”.

If the shed is smaller, you probably weave too close to the reed and (or) the tension on the warp is too high.

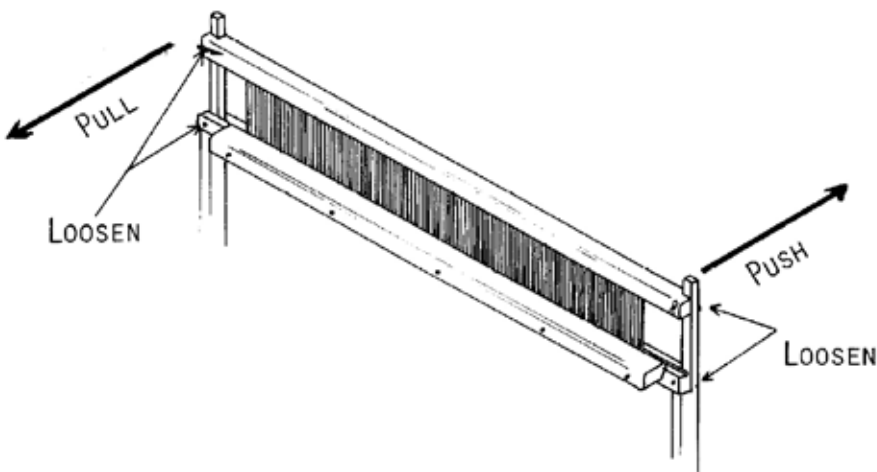
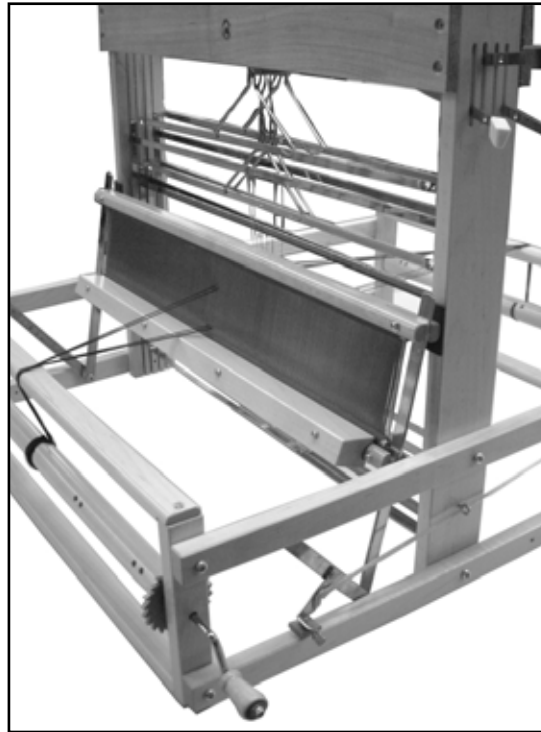
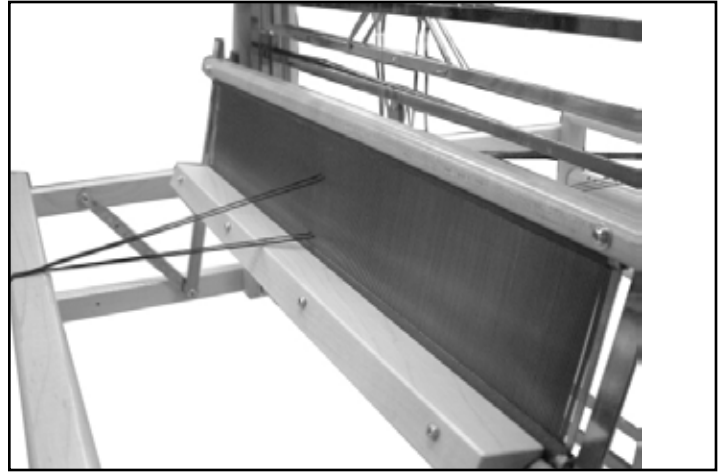

The beater has been adjusted at the factory before shipping. If the batten doesn't touch the two bumpers equally, loosen the bolts of the batten sley and batten handtree and exert pressure on the batten centering it in its proper place. Tighten the bolts again while keeping pressure on the batten.

PREPARING (Stringing) WARP AND CLOTH BEAMS

1) Into 5 evenly chosen holes on each beam, thread one length of the loop cord.

2) Thread each loop cord back through itself, using the first hole in the Cord, as it comes out of the beam and pull tight.

3) Using the last hole of the free end on each Cord, pull a portion of the Cord through the hole forming a Loop. (A crochet hook can help you)

4) Slip a Bar through each loop of all cords and pull tight. (See diagram)

All Cords should be exactly the same length in order to make an even tension.

Always maintain a good tension on the warp when weaving.

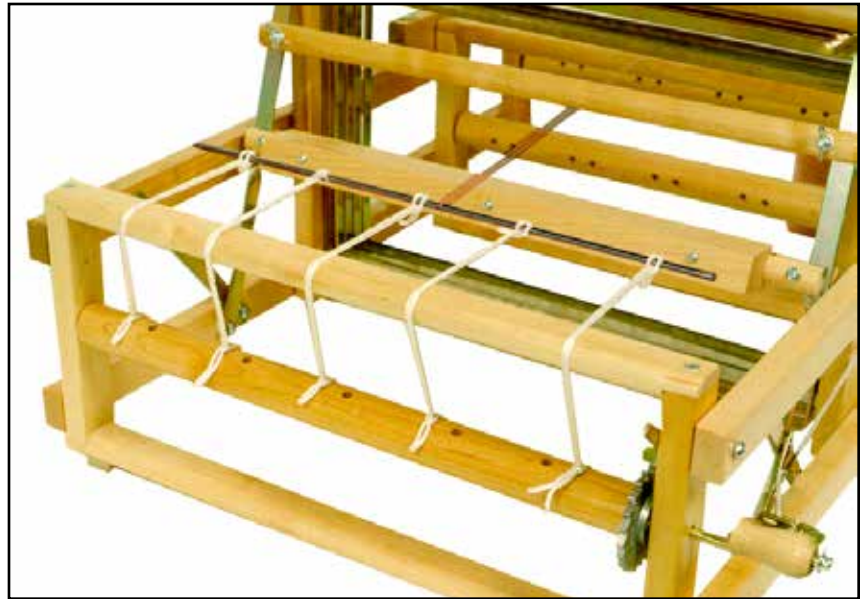
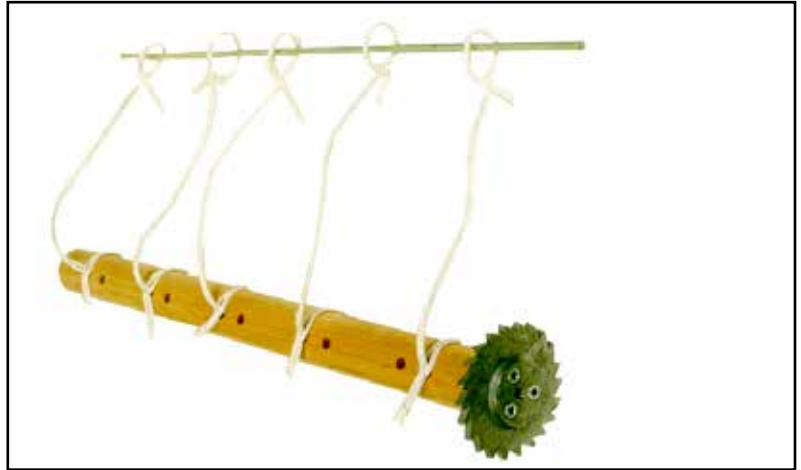

Warp beam advance control system



This system will eliminate excessive warp yarn advance when releasing the brake system at cloth take-up. This friction system is adjustable and has to be released when winding the warp on. Just screw the wing nut with nylon bolt to the left back post. Screw in to increase the friction or unscrew it to release.

PROMPTLY CALL YOUR DEALER OR LECLERC FOR ANY QUESTIONS.

LECLERC LOOMS

P.O. BOX 4

1573 Savoie

PLESSISVILLE QC. CANADA

G6L 2Y6

819-362-7207

Fax: 819-362-2045

courriel: info@leclerclooms.com

www.leclerclooms.com